

TAH-100

UNIT SPECIFICATIONS:

POWER SUPPLY: 208V/3PH/60Hz/78MCA
 230V/3PH/60Hz/70MCA
 460V/3PH/60Hz/35MCA

AIR DELIVERY: 20,000 CFM
 MAX ESP (IN W.C.): 3.50 @ 20,000 CFM
 DRAIN CONNECTION: 2" NPT

DIMENSIONS:

LENGTH (IN): 120
 WIDTH (IN): 100
 HEIGHT (IN): 83
 WEIGHT (LBS): 5,165

UNIT COMPONENTS:

- (A) RETURN AIR
- (B) SUPPLY AIR $\phi 20$
- (C) SAFETY DISCONNECT
- (D) SUPPLY CONNECTION $\phi 4"$ 150#
- (E) RETURN CONNECTION $\phi 4"$ 150#
- (F) CONDENSATE DRAIN CONNECTION

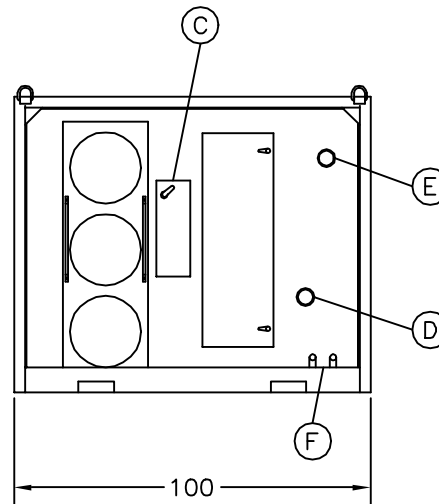
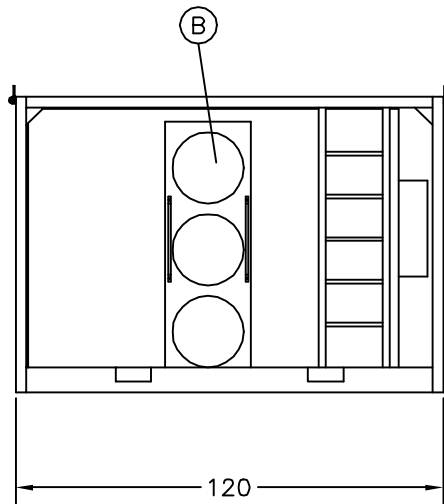
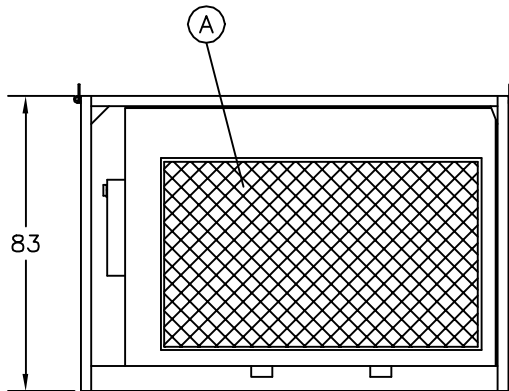

DRAWN: ACJ	APPROVED: DLG	DRAWING NUMBER: TAH100
DATE: 07.02.02	DATE: 07.03.02	