

MIDFO-1000

UNIT SPECIFICATIONS:

GENERATOR: 8 kW, 60 Hz, 1 Ph, 1800 RPM
120-240 V/33A, 120 V/66A
0.94 GPH @1800 RPM

HEATERS (EACH): 500,000 BTU, 3,100 CFM,
170 DEG RISE, 3.0 GPH, 450 LBS

FUEL SUPPLY:

FUEL TYPE: DIESEL
FUEL TANK: 150 GAL
FUEL OIL TYPE: #1
FUEL CONNECTION: 1/4" NPT

DIMENSIONS:

LENGTH (IN): 198
WIDTH (IN): 98
HEIGHT (IN): 95
WEIGHT (LBS): 5140

UNIT COMPONENTS:

- (A) FLUE EXHAUST
- (B) SERVICE ACCESS HEATERS
- (C) 8 kW GENERATOR
- (D) JACKS
- (E) LIFTING EYES
- (F) SERVICE ACCESS HEATERS
- (G) INTERNAL FUEL TANK 150 GALLON

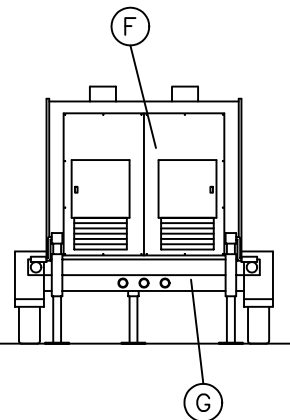
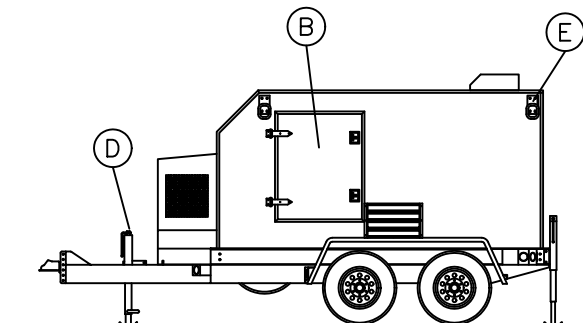
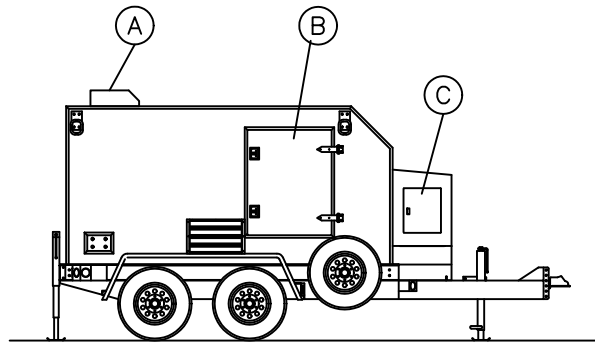

DRAWN: JT	APPROVED: DLG	DRAWING NUMBER:
DATE: 8-31-06	DATE:	MIDFO-1000