

# TAH-100

## UNIT SPECIFICATIONS:

POWER SUPPLY: 208V/3PH/60Hz/78MCA  
230V/3PH/60Hz/70MCA  
460V/3PH/60Hz/35MCA

AIR DELIVERY: 20,000 CFM  
MAX ESP (IN W.C.): 3.50 @ 20,000 CFM  
DRAIN CONNECTION: 2" NPT

## DIMENSIONS:

LENGTH (IN): 120  
WIDTH (IN): 100  
HEIGHT (IN): 83  
WEIGHT (LBS): 5,165

## UNIT COMPONENTS:

- (A) RETURN AIR
- (B) SUPPLY AIR  $\phi 20$
- (C) SAFETY DISCONNECT
- (D) SUPPLY CONNECTION  $\phi 4"$  150#
- (E) RETURN CONNECTION  $\phi 4"$  150#
- (F) CONDENSATE DRAIN CONNECTION

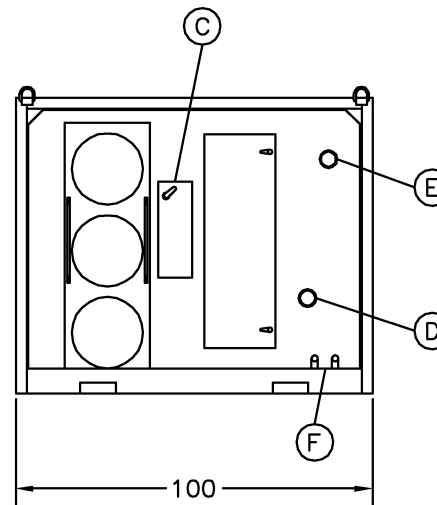
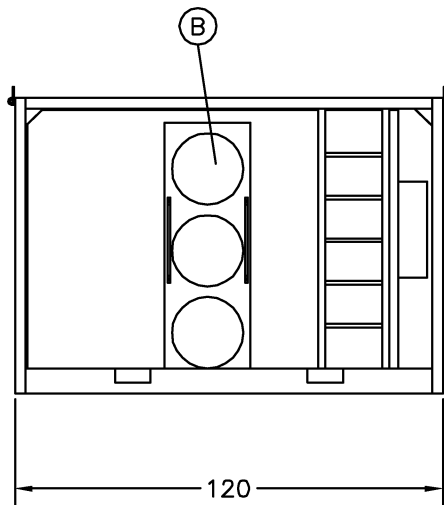
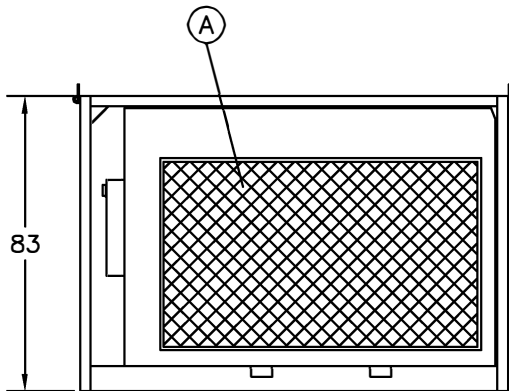

DRAWN: ACJ

APPROVED: DLG

DRAWING NUMBER:

DATE: 07.02.02

DATE: 07.03.02

TAH100